

LAWSON
INDUSTRIES, INC.

LA PORTE

French Door

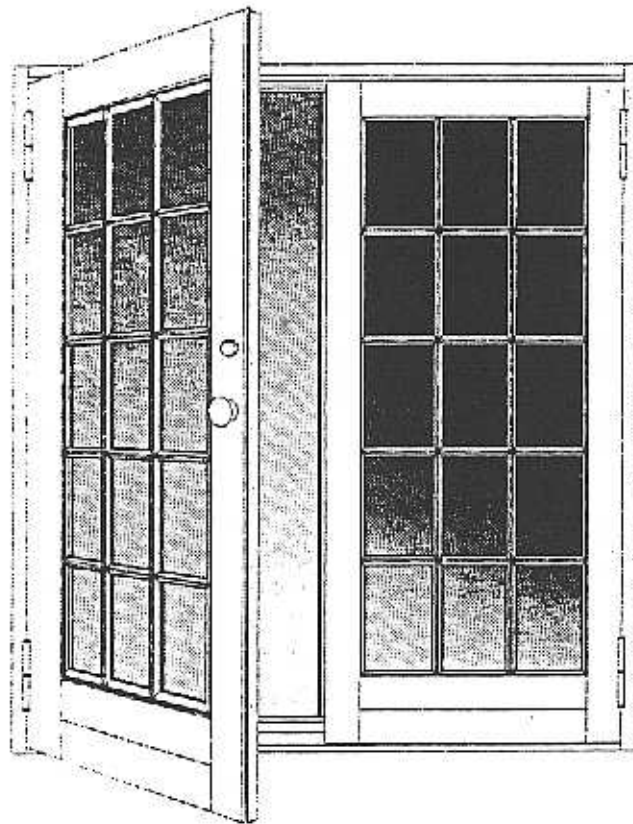

INSTALLATION MANUAL

PLEASE READ ENTIRE MANUAL BEFORE PROCEEDING

EIGHT FOOT HIGH UNITS, AND UNITS CONTAINING ONE OR MORE SIDE LITES MAY REQUIRE A TWO PERSON INSTALLATION CREW TO SET FRAME AND PLACE PANELS INTO POSITION.

LA PORTE

INSTALLATION INSTRUCTIONS

NOTE: ALL HANDING IS VIEWED FROM EXTERIOR

I. Opening

- Bucks must comply with local code in size, placement and method of attachment to masonry. Lower end of buck must not bottom out in depression.
- A recess of at least 1 1/2" below inside floor is desirable to help prevent water penetration. Sill of depression should be level, flat and free of protrusions in corners. **See figure #1.**
- Size of opening is shown in Lawson brochure. Check size against opening, by measuring height and width in three places.

II. Frame Assembly

- Open frame package and inspect extrusion.
- Check size of each component against packing slip.
- Lay out the four frame pieces by placing each down on a clean flat surface. All weatherstrip must face up. Sill must be at bottom; head at top. Hinge slots in jambs are identified by measuring the distance of each jamb hinge slot from its end. **See figure #2.**
- Secure each jamb to sill and header using 2 ea. #12 x 3/4" S.M.S. per corner. Check frame to assure that frame is square and that joints are fully closed. Caulk jamb to sill joint from back side (under side) of sill using an A.A.M.A. approved caulking compound. **See figure #3.** You may also seal sill to jamb from the front side using an A.A.M.A. approved or joint sealer.

III. Side Lites

Read the entire paragraph before proceeding: If your unit does not contain side lites, skip to step IV.

- Layout side lite as in step #2.
- Adaptor of side lite always faces, and will later attach to door. **See figure #4.**
- Assemble side lite as in II D.
- Caulk back side of side lite that will marry up directly with jambs of door. Caulk along entire length of side lite adaptor's exterior leg use A.A.M.A. approve caulk. **See fig. #4 & 5.**
- Link up side lite to door. (Be sure that adaptor is in full contact with back side of door jamb.) Jags on back of jamb must match with legs of adaptor. Caulkings should not be visible after linking up. **See figure #5.**
- Secure sidelite jamb to door jamb using 4 #10 x 3/4" S.M.S. Locate two screws approx. 3/4" from both top and bottom of jamb.

FIGURE 1

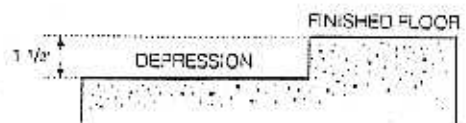

FIGURE 2

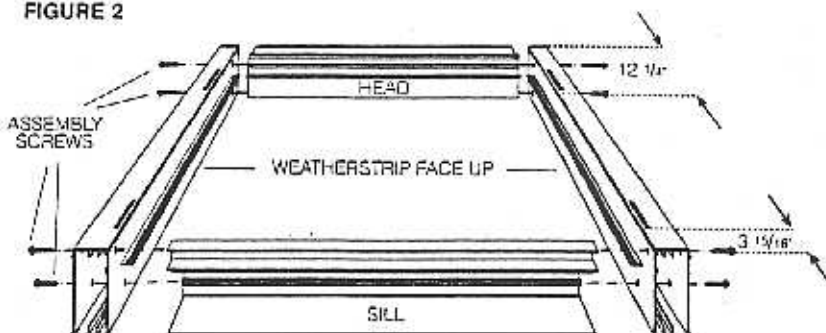

FIGURE 3

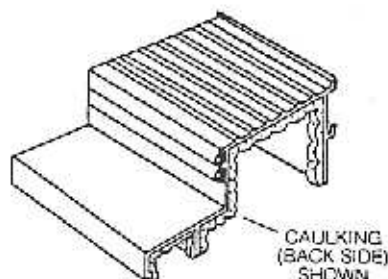

FIGURE 4

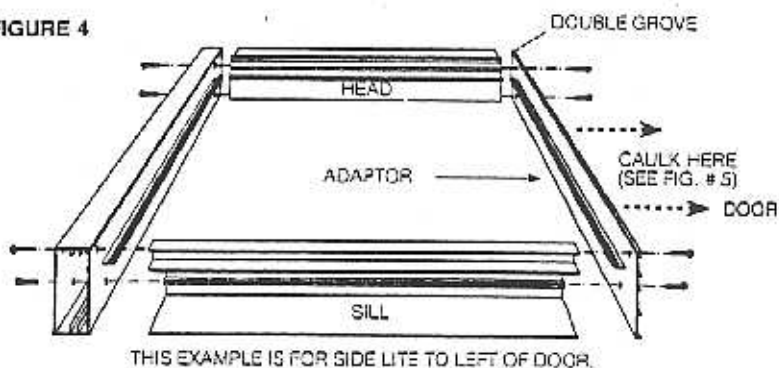
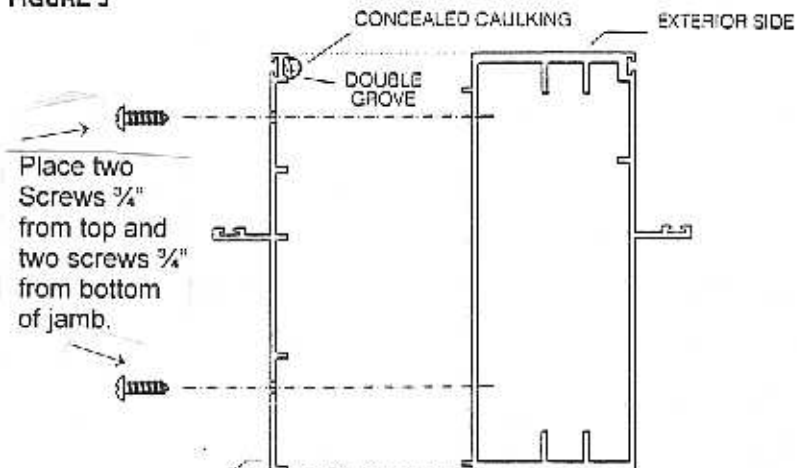

FIGURE 5



IV. Frame Installation

FIGURE 6

- A. Lay a bed of premixed wet non-shrink cement into depression. Move cement side to side and front to back. Push cement against vertical back leg of depression and into all corners. Fill all honeycomb breakouts and trowel from lowest point until bed is level and is approximately 1 1/2" deep. See figure #6.



- B. Stand frame up and side lite as one unit, and move to opening.

- C. Raise entire unit up, and hold header of unit hard against header buck. Align frame header and jamb to approximate center of header and jamb bucks.

FIGURE 7

- D. Lower entire frame so that sill sinks into cement do not force frame down, but allow cement to penetrate. Up and into open cavity in underside of sill. Sill should sink to a depth of approximately 1" into cement.

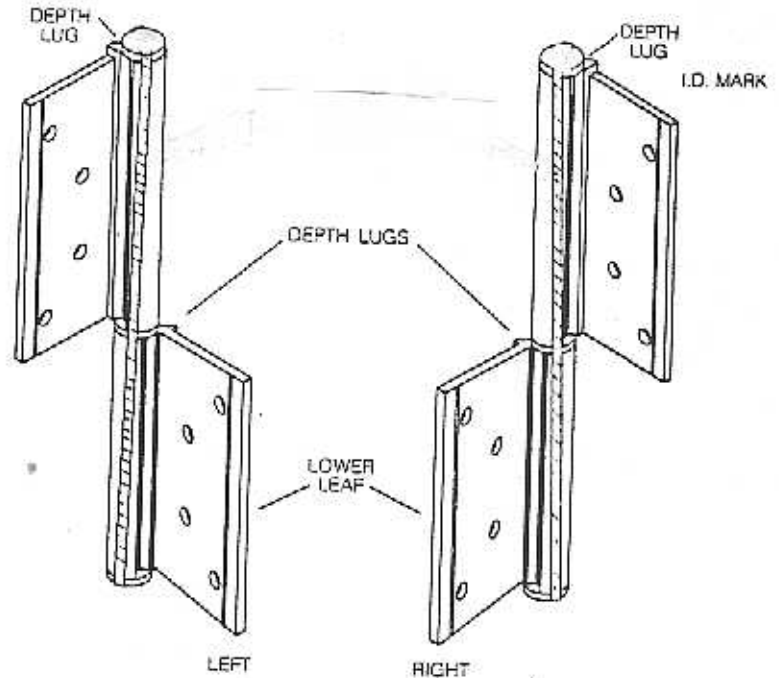

- E. Install one masonry screw through the far right and one masonry screw through the far left pre-punched sill holes. Screw down through the wet grout and into the depression. Check sill with level.

- F. Place level against jamb and shift frame accordingly to plumb up.

- G. Using the two pre-punched screws holes in the header that are closest to each jamb, install two #12 x 2" long installation screws. Do not run the screws full home, but only to a depth sufficient to prevent the frame from falling out of the opening. Make lateral movement of the frame if necessary.

- H. Check frame height and width in three places. Measure diagonal dimension from corner to corner of frame. Adjust accordingly.

- I. When frame is plumb, level and measurements equal; install remaining header and jamb screws. Complete sill installation when grout has full set up.

V. Preparation For Panel Installations:

Hinge kit contains:

- 2 right hinge assemblies. See fig. #7.
- 2 left hand hinge assemblies
- 32 #10 x 5/8" truss head screws

FIGURE 8

- A. Slide lower left of one hand hinge assembly into the bottom slot of the left hand jamb. See fig. #8.
- B. Repeat A and B with one lower right hand hinge assembly.
- D. Lift top leaf from each hinge. Stainless Steel hinge pin with "C" ring must remain in lower half of each jamb hinge assembly. Set both upper leaves aside for installation when you reach step # VI H.

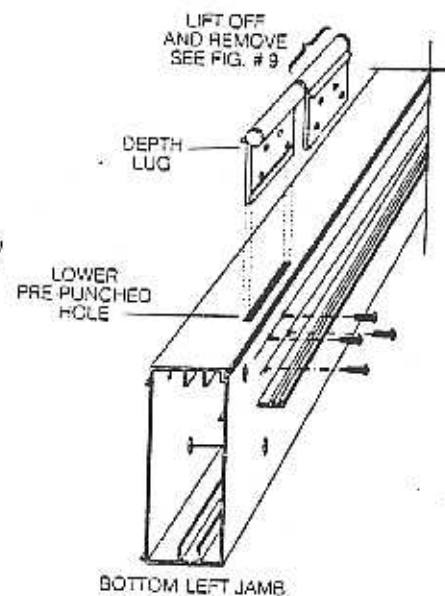

- E. Remove all packing and protection from panel.
- F. Place active panel (panel with latch hole) and inactive panel (panel without latch hole) in upright position. Determine top from bottom, and inside from outside.

VI. Measuring Panel

- A. Measure panel width and height in three places. Measure panel diagonals. Visually check to assure that panel is flat and that horizontals join vertical at 90 degree, and that there are no tension induced warps in panel. If panel is not square and free of warp, the panel will not seal against frame properly.
- B. If panel has any of the above distortions, remove top and bottom access hole plugs in the hinge stile of the panel.
- C. Insert a 3/8" diameter socket wrench into the access hole, and loosen the hex nut holding the washer against the threaded horizontal panel stretcher. **See fig. #9 & #10.**
- D. When nut spins freely and washer is away from the hex nut, tap opposite corners of panel until the panel corner realigns properly. Check for absence of warp.
- E. Retighten hex nut and replace access hole cover.
- F. Slide upper leaf of left hand hinge into the pre-punched slot of the left hand panel. Secure to door stile with (4) #10 x 3/4" S.M.S. Note: Do not remove the rubber retaining band from either top panel assemblies.
- G. Repeat same step using right hand hinge assembly for right hand panel. Do not remove the rubber retaining band from panel hinge assemblies.
- H. Repeat top leaf of lower jamb hinge assembly removed in step V D., insert into lower prepunched slot of left hand door panel. Secure with (4) #10 x 5/8" S.M.S.
- I. Repeat with remaining right hand hinge leaf for right hand door panel. **See fig. #10.**
- J. Raise inactive panel and slide lower panel hinge leaf down onto stainless steel hinge pin of inactive door jamb until fully seated on pin. Push top of panel toward jamb, guiding leaf of top hinge of panel to enter slot in top of jamb. Secure with (4) #10 x 5/8" S.M.S.
- K. Repeat with active panel as in step VI J.
- L. Close the inactive panel and activate both flush bolts in the concealed face of the inactive panel.
- M. Measure the top and bottom reveals of the panel to the header and sill. If the reveals are not even, the panels will not align properly. Refer back to steps VI H and I for corrective action.

FIGURE 9

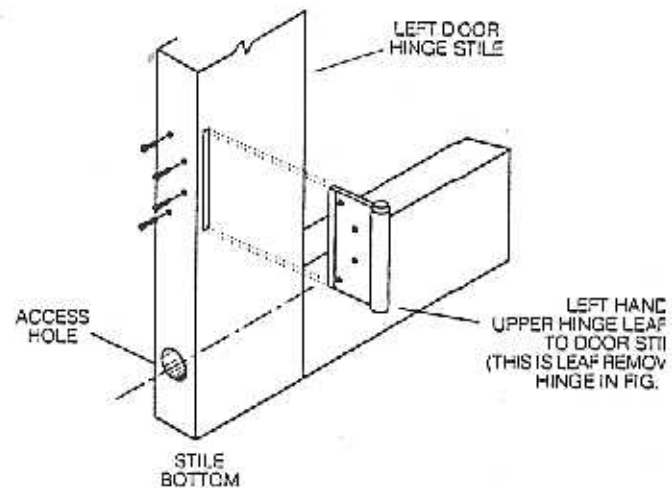
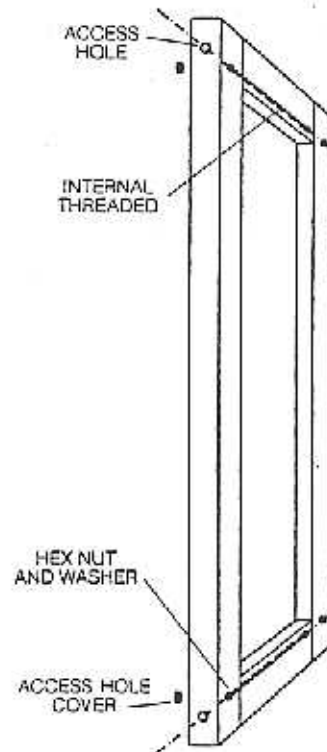

FIGURE 10



VII. Hardware

Your door has been prepared at the factory with two each 2 1/8" diameter holes in each active panel for a 2 3/8" standard backset. The top holes is for the dead bolt. Install hole plug covers in all access holes.

VIII. Care and Cleaning

Your Lawson La Porte french door is virtually maintenance free other than for occasional lubrication of the hinge, latch and flush bolts. Open both doors to full open position at least once each month. Clean the sill of any dust, sand or debris that may accumulate. Clean glass and metal surfaces with warm water and a mild detergent. Do not use abrasives of any sort nor exotic chemicals that could cause paint to blister or dull. Be sure to completely flush door to remove any residual detergent. Units that are exposed to a salty environment may require more frequent care. Relubricate hinge, latch and flush bolt after cleaning.

Replacement parts are available through better glass shops, door and or window companies. Consult your local yellow pages for listings.

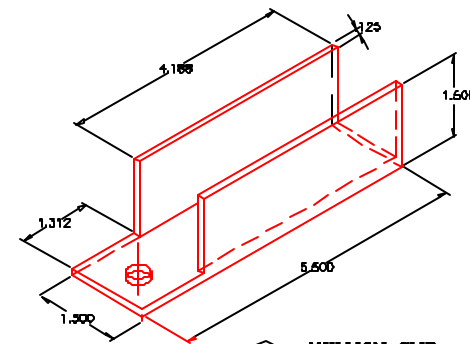
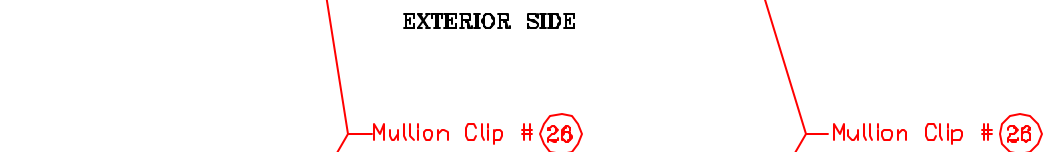
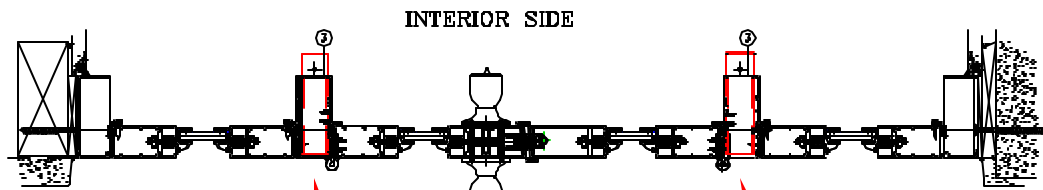

26 MULLION CLIP #FD-831

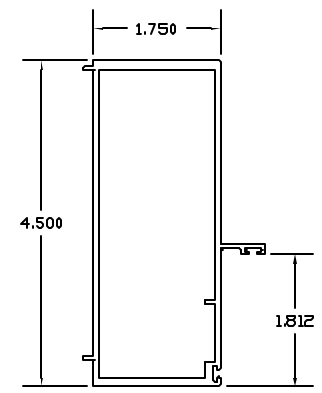

3 FRAME JAMB #L-903

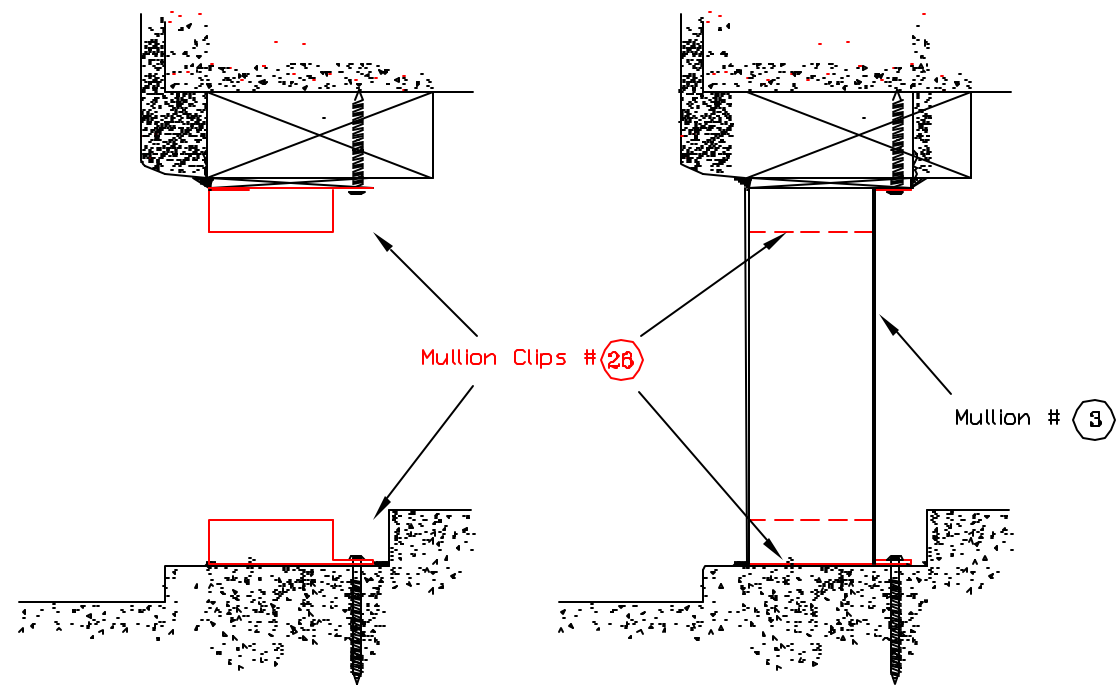
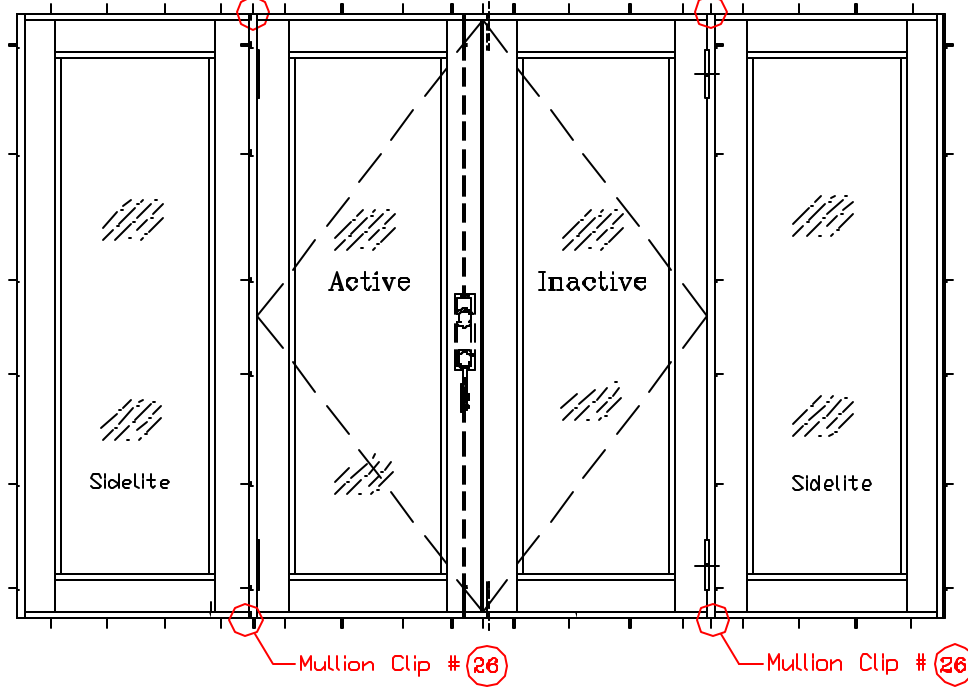

"OXXO" PLAN & ELEVATION

Mullion clip # 26 shall be installed at top and bottom of each La Porte mullion using 1/4" X 2-1/2" tapcons.

THOMAS J. SOTOS
PROFESSIONAL ENGINEER
FL LIC. # 56225

Revision Notes:

LAWSON
INDUSTRIES, INC.

8501 NW 90th St.
MEDLEY, FLORIDA 33166
(305) 696-8660

MANUFACTURER OF QUALITY ALUMINUM WINDOWS AND GLASS DOORS

Drawn Class:	Part Name:	Prod. Designation:	Series/Model:	Sheet:	Sheet:
APPROVALS		IMPACT	FRENCH DOOR		1 OF 1

"La Porte" Mullion Clip Installation

DATE _____

Checked By:	Date Checked:
Drawn By: Tom Sotos	Date Drawn: 10/23/06
Scale:	Scale:
N.T.S.	

Part Number	Drawing Number	Revision Level
		"A"

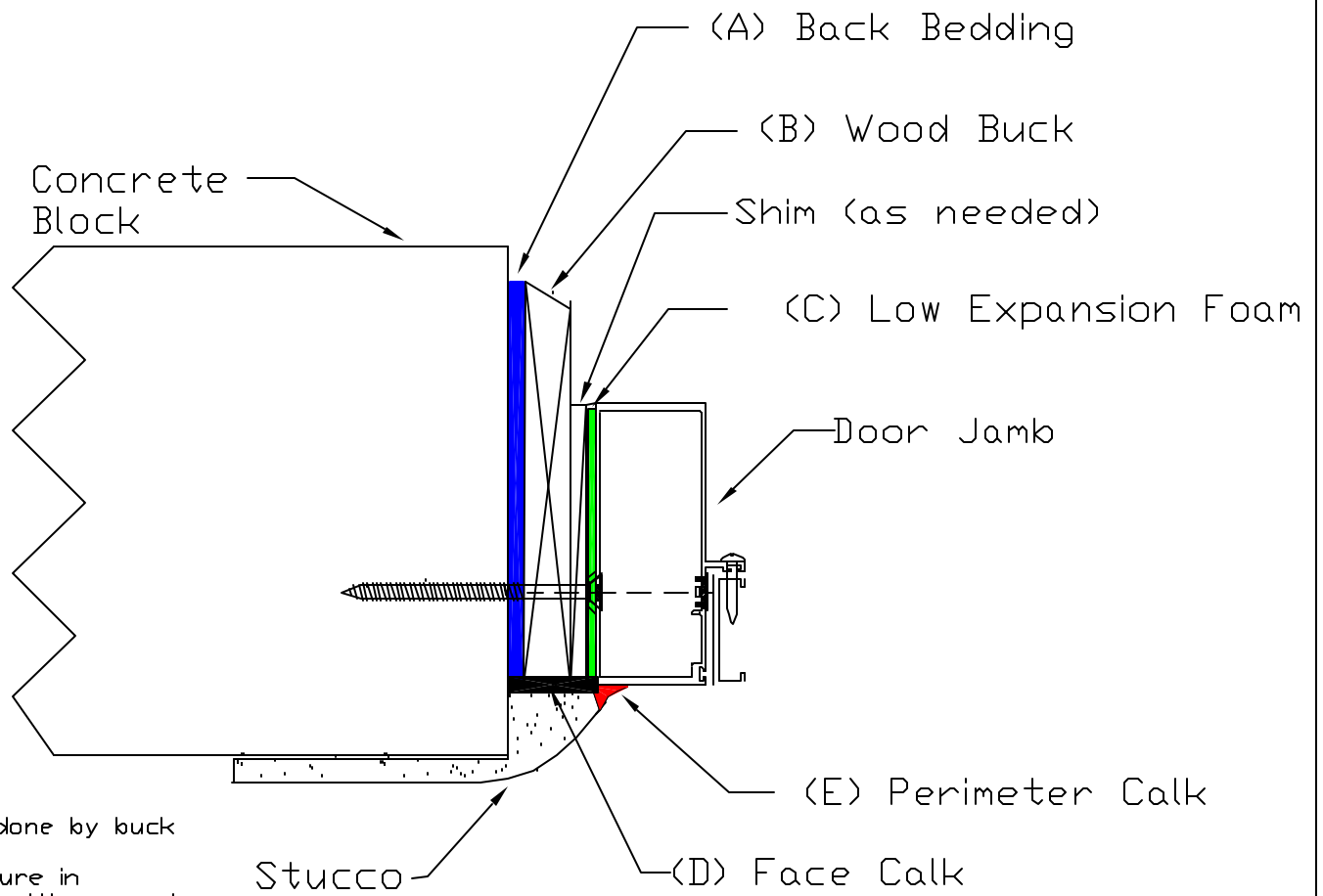

- (A) Back bedding of jamb buck to block is done by buck installer.
- (B) Wood Buck must be anchored to structure in accordance with trade practice, and comply with governing building code. Bottom end of wood buck MUST BE $\frac{1}{2}$ " ABOVE TOP of interior concrete floor. Buck NEVER extends down into depression.
- (C) Any VERTICAL space between door and jamb and jamb and buck is to be filled with a low expansion foam. (not by door installer). The cavity between the block wall and BOTTOM of door jamb must be filled with a polyurethane or equal material.
- (D) Face caulk using a urethane or equal material must extend from jamb to block. (not by window installer)
- (E) Perimeter caulk protects seam where stucco meets jamb or door. (not by window installer)

Commercial tolerances apply unless noted otherwise.
 Notched wall: 2x4/2x6/2x8/2x10/2x12
 Break sheets between U.O.I.S unless noted otherwise.

Structure Notes: Partitions: 0.000 Material: 0.000 Co-ty: 0.000 Frame Sp: Tom Sotos Window Sp: 0.000 Finish: 0.000				Lawson Industries, Inc. 8501 N.W. 90 ST. MEDLEY, FLORIDA 33108 PH No. (305) 898-8800 MANUFACTURERS OF QUALITY ALUMINUM WINDOWS AND GLASS DOORS			
Division: 0.000 Sub-division: 0.000 Section: 0.000 Detail: 0.000	Division: 0.000 Sub-division: 0.000 Section: 0.000 Detail: 0.000	Division: 0.000 Sub-division: 0.000 Section: 0.000 Detail: 0.000	Division: 0.000 Sub-division: 0.000 Section: 0.000 Detail: 0.000	Division: 0.000 Sub-division: 0.000 Section: 0.000 Detail: 0.000	Division: 0.000 Sub-division: 0.000 Section: 0.000 Detail: 0.000		
Part Number: XXXXXX			Drawing Number: XX-XX-XX				

GENERIC DOOR WATERPROOFING PRACTICE